



## VTXB 1 - B09 - 1 R 00 - D 1 02 \*

### Series

### Mounting

- 1 - SAE A
- 2 - SAE B

### Cam ring

Volumetric displacement  $\text{cm}^3 / \text{rev}$  ( $\text{in}^3 / \text{rev}$ )

- B02 = 5.8 (0.35)
- B03 = 9.8 (0.59)
- B04 = 12.8 (0.78)
- B05 = 15.9 (0.97)
- B06 = 19.8 (1.21)
- B07 = 22.5 (1.37)
- B08 = 24.9 (1.52)
- B09 = 28.0 (1.71)
- B10 = 31.8 (1.94)
- B11 = 34.9 (2.13)
- B12 = 41.0 (2.50)(cont. 175 bar, Max. int 210 bar)
- B14 = 45.0 (2.75)(cont. 140 bar, Max. int 175 bar)

### Type of Shaft

#### TXB1

- 1 - Keyed (Non SAE)
- 2 - Keyed
- 3 - Splined
- 4 - Splined
- 5 - Keyed
- V - Splined

#### TXB2

- 1 - Keyed (Non SAE)
- 2 - Keyed
- 4 - Splined

### Direction of rotation (view on shaft end)

- R - clockwise
- L - counter-clockwise

### Modifications

### Port connections

CODE	S	P
00	SAE 20 1" 5/8 12 UNF-2B	SAE 12 1" 1/16 12 UNF-2B
01	1" 1/4 SAE 4 bolt (UNC)	3/4" SAE 4 bolt (UNC)
M0	1" 1/4 SAE 4 bolt (METRIC)	3/4" SAE 4 bolt (METRIC)
02	1" 1/4 BSP	3/4" BSP
03	1" 1/4 NPTF	SAE 12 1" 1/16 12 UNF-2B
0X	1" 1/4 NPTF	3/4" NPTF
MX	Ø28 SAE 4 bolt (METRIC)	Ø15 SAE 4 bolt (METRIC)

### Seal class

- 1 - S1 (for mineral oil)
- 4 - S4 (for fire resistant fluids)
- 5 - S5 (for mineral oil and fire resistant fluids)

### Design letter

### Porting combination

00 - standard

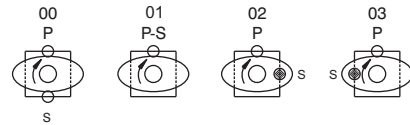

**S - Suction port P - Pressure port**

## OPERATING CHARACTERISTICS (24 cSt)

Pressure port	Series	Volumetric Displacement $V_p$		Flow $q$ & $n = 1500 \text{ rpm}$						Input power $p$ & $n = 1500 \text{ rpm}$					
		$\text{in}^3 / \text{rev}$	$\text{cm}^3 / \text{rev}$	$p = 0 \text{ bar (0 psi)}$		$p = 140 \text{ bar (2000 psi)}$		$p = 210 \text{ bar (3000 psi)}$		$p = 7 \text{ bar (100 psi)}$		$p = 140 \text{ bar (2000 psi)}$		$p = 210 \text{ bar (3000 psi)}$	
				gpm	lpm	gpm	lpm	gpm	lpm	hp	kw	hp	kw	hp	kw
VTXB1 VTXB2	B02	0.35	5.8	2.30	8.7	1.4	5.9	--	--	0.53	0.4	2.81	2.1	--	--
	B03	0.59	9.8	3.88	14.7	2.9	11.9	--	--	0.67	0.5	3.62	2.7	--	--
	B04	0.78	12.8	5.08	19.2	4.33	16.4	3.97	15.0	0.93	0.7	5.23	3.9	10.06	7.5
	B05	0.97	15.9	6.31	23.8	5.55	21.0	5.18	19.6	1.00	0.75	6.64	4.9	11.2	8.3
	B06	1.21	19.8	7.85	29.7	7.12	26.9	6.66	25.2	1.07	0.8	8.05	6.0	12.34	9.2
	B07	1.37	22.5	8.92	33.7	8.17	30.9	7.80	29.5	1.20	0.9	9.05	6.7	14.02	10.4
	B08	1.52	24.9	9.89	37.4	9.15	34.6	8.78	33.2	1.34	1.0	10.05	7.5	15.69	11.7
	B09	1.71	28.0	11.11	42.0	10.37	39.2	10.00	37.8	1.47	1.1	11.94	8.9	23.60	17.6
	B10	1.94	31.8	12.61	47.7	11.87	44.9	11.51	43.5	1.6	1.2	13.0	9.7	26.0	19.6
	B11	2.13	34.9	13.85	52.3	13.09	49.5	12.72	48.1	1.7	1.3	14.0	10.5	28.0	21.0
	B12	2.50	41.0	16.27	61.5	15.53	58.7	*	*	1.8	1.4	15.02	11.2	*	*
	B14	2.75	45.0	17.86	67.5	17.12	64.7	**	**	2.1	1.6	15.42	11.5	**	**

-- Not to use because internal leakage greater than 50% of theoretical flow.

\* B12= 210 bar(3000 psi) Max.Int

\*\* B14= 175 bar(2500 psi) Max.Int

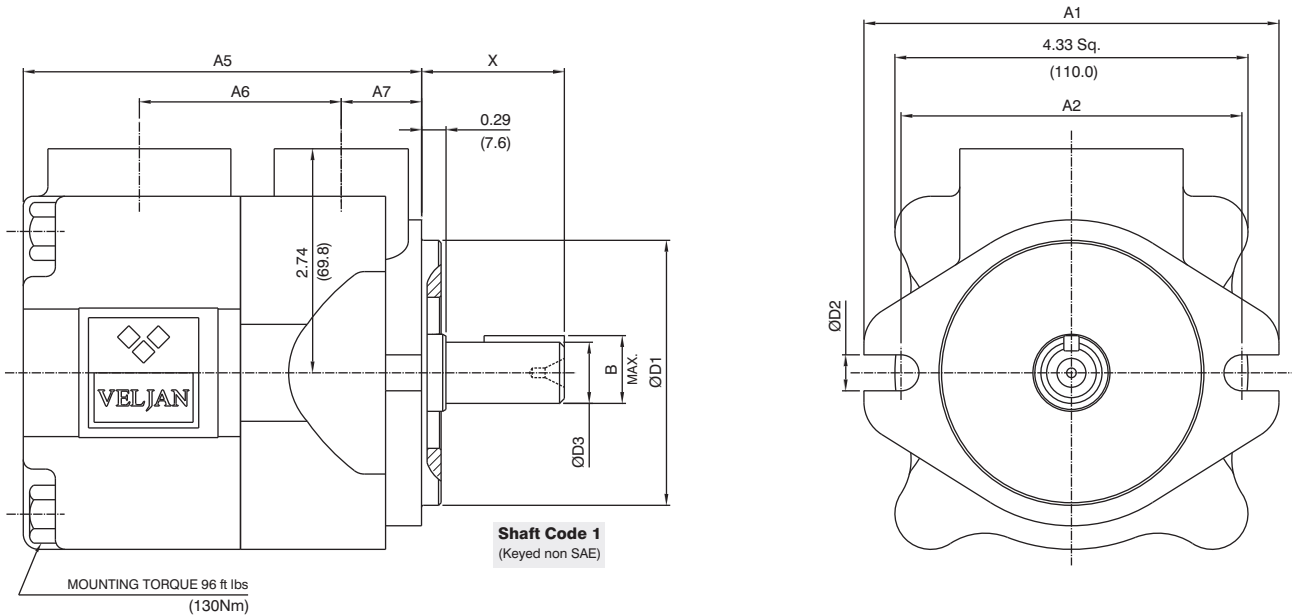
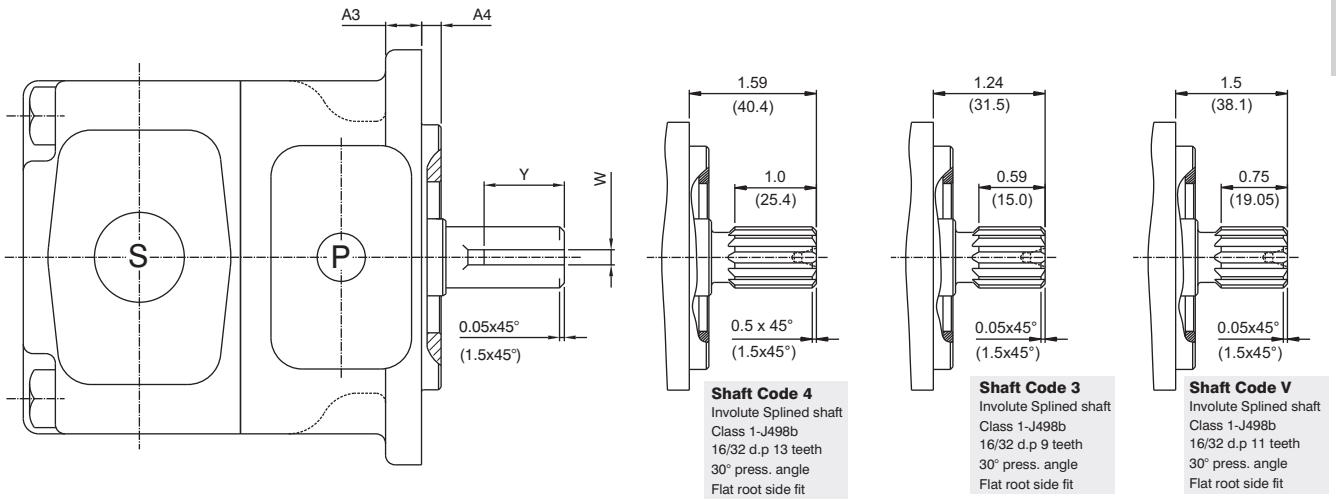

DIMENSIONS OF KEYED SHAFT in inches (mm)						
MODEL	CODE	X	Y	ØD3	B	W
TXB1	1	1.75(44.5)	0.98(25)	0.75/0.74(19.05/19.00)	0.83(21.1)	0.187/0.185(4.75/4.70)
	2	1.96(50.0)	0.98(25)	0.625/0.624(15.88/15.85)	0.69(17.7)	0.156/0.155(3.97/3.94)
	5	2.66(67.6)	1.61(41)	0.75/0.74(19.05/19.00)	0.83(21.1)	0.187/0.185(4.75/4.70)
TXB2	1	2.32(59.0)	1.25(32)	0.875/0.874(22.22/22.20)	0.96(24.5)	0.187/0.185(4.75/4.70)
	2	2.81(71.4)	1.49(38)	0.875/0.874(22.22/22.20)	0.96(24.5)	0.250/0.248(6.35/6.30)

DIMENSIONS in inches (mm)									
MODEL	A1	A2	A3	A4	A5	A6	A7	ØD1	ØD2
TXB1	5.11(130.0)	4.18(106.2)	0.44(11.2)	0.24(6.1)	4.88(124.1)	2.47(62.9)	0.98(25.0)	3.25/3.24(82.55/82.50)	0.44(11.2)
TXB2	6.87(174.5)	5.74(146.0)	0.5(12.7)	0.38(9.7)	4.94(125.6)	2.29(58.4)	1.22(31.0)	4.00/3.99(101.60/101.55)	0.56(14.3)

SP

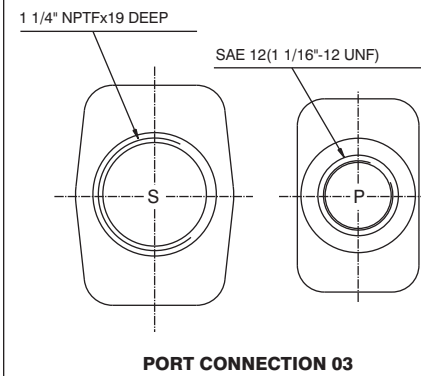
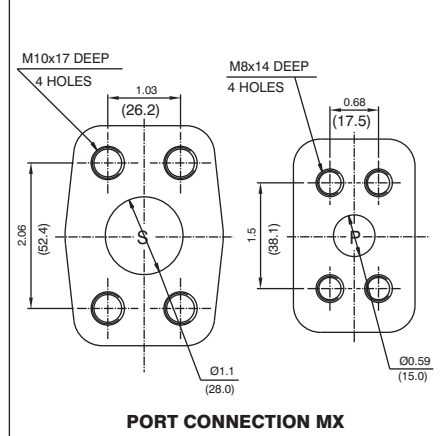
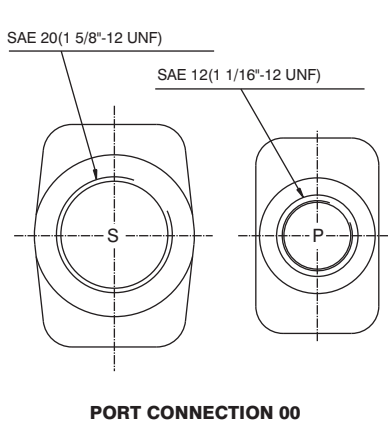

### INTERNAL LEAKAGE (TYPICAL)

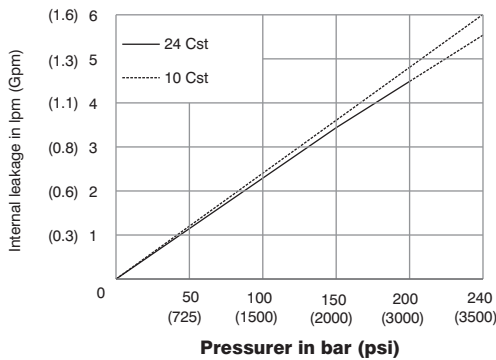

Do not operate pump for more than 5 seconds at any speed or viscosities if internal leakage is more than 50% of theoretical flow.

### NOISE LEVEL (TYPICAL)

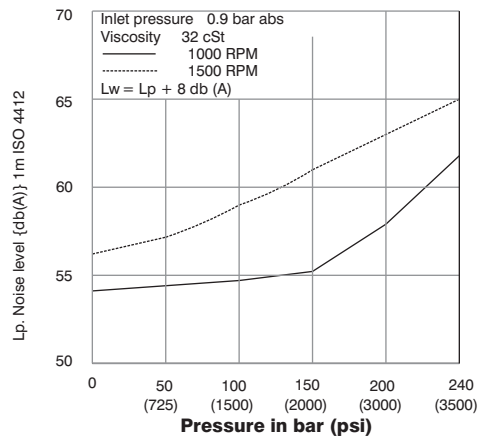

### POWER LOSS HYDROMECHANICAL (TYPICAL)

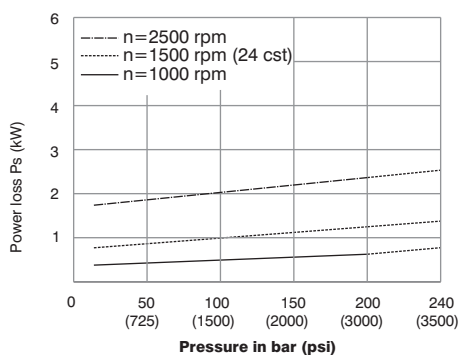

### PERMISSIBLE RADIAL LOAD

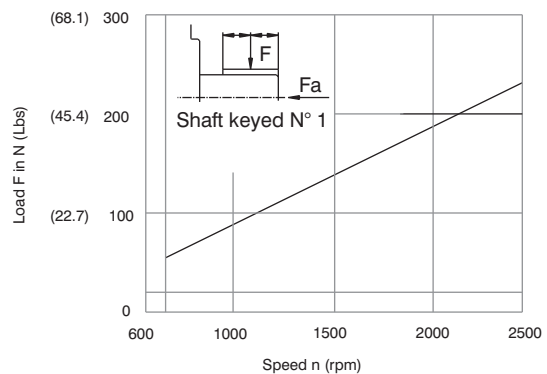

Maximum axial load permissible  $F_a = 500 \text{ N (113.6 lbs)}$